

Desigo™ TRA

Airflow Pressure Sensor

DXA.S04P1...

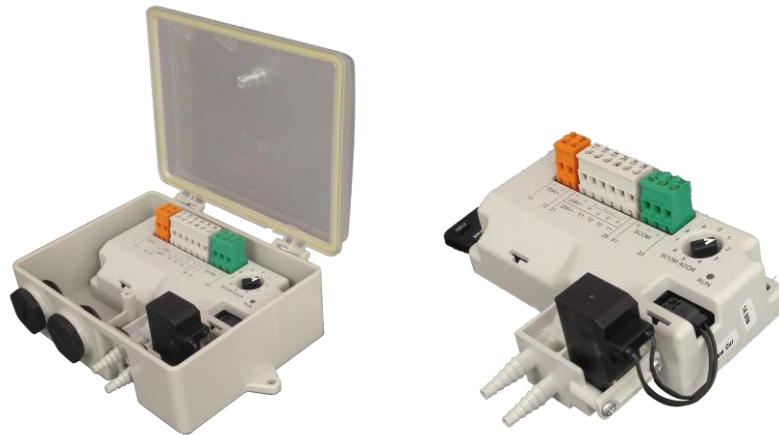

Airflow Pressure Sensor (APS) is used to measure airflow for room pressurization and fume hood control applications.

- Differential Pressure (velocity) is measured by a diaphragm type transducer
- Communicates with the controller over a dedicated RS-485 digital bus
- Auto-zero feature to calibrate sensor

Features

- Rotary address switch
- Actuator connection terminal block
- SCOM communication
- Red and green LED status light
- Auto-zero function
- OVER-RANGE detection
- UNDER-RANGE detection
- Airflow sensing range 0...1"WC (250 pa)

Use

The differential pressure sensor is used to measure duct velocity pressure. The auto-zero solenoid is internally connected to the air velocity pressure transducer's inlet ports to enable automatic periodic re-calibration. This re-calibration ensures accurate, drift-free airflow measurement. Automatic re-calibration of the differential pressure transducers occurs upon system power-up and when airflows are stable with configurable frequency based on hours, default is every 3 hours.

Functions

Auto-zero

The auto-zero sequence can be initiated by any of the following:

- Commanding BACnet object properties
- Configured time delay
- APS power on or return from power loss

The auto-zero sequence automatically adjusts the internal offset for the differential pressure sensor.

Reliability states

The APS reports all reliability states to the DXR2, including:

- BAD_CALIBRATION
- BAD_TRANSDUCER
- LOW_PRESSURE
- HIGH_PRESSURE
- CAL_IN_PROGRESS
- RESET_OCCURED
- BAD/NO COMM
- COMMUNICATION_FAILURE

LED Indication

Air sensor calibration blink pattern takes precedence over the communication blink pattern.

LED State	Status
Green – solid	Running, no communication
Green – blink 80/20	Running, communication ok
Green – blink 50/50	Air sensor calibration mode
Red – solid	Error condition

Technical design

Connectors

- Power Connector – two position power (Orange)
- I/O pass-through connector – six position I/O (Gray)
- SCOM Connector – three position SCOM (Green)

Sensor bus communication (SCOM)

- RS-485 topology
- 115.2 kbps

IP54 Kit

- clear cover enabling LEDs to be visible
- liquid tight cablegrips
- conduit plugs

Type summary

Type	Order number	Enclosure rating	Outputs
DXA.S04P1	S55376-C139	IP20	1 Digital comm. (sensor bus)
DXA.S04P1-B	S55376-C140	IP54	1 Digital comm. (sensor bus)

Delivery

The DXA.S04P1-B includes an IP54 rated enclosure, liquid tight cordgrip (2) and conduit plug.

Product documentation

Topic	Title	Document ID:
Mounting instructions	Air Pressure Sensor	A6V10959863
Engineering and commissioning, workflow	ABT online help	n.a.
Commissioning	User's guide: Setup & Service Assistant (SSA)	CM111050

Related documents such as environmental declarations, CE declarations, etc., can be downloaded at the following Internet address:

<http://siemens.com/bt/download>

Notes

Security

	⚠ CAUTION
	National safety regulations Failure to comply with national safety regulations may result in personal injury and property damage <ul style="list-style-type: none">• Observe national provisions and comply with the appropriate safety regulations.

Mounting

Typical mounting locations:

- On a duct, terminal box or air valve
- In an equipment closet
- On top of a fume hood
- On wall, in an equipment room
- Partly conditioned space (above the ceiling)

Standard mounting: The APS unit can be mounted in any orientation.

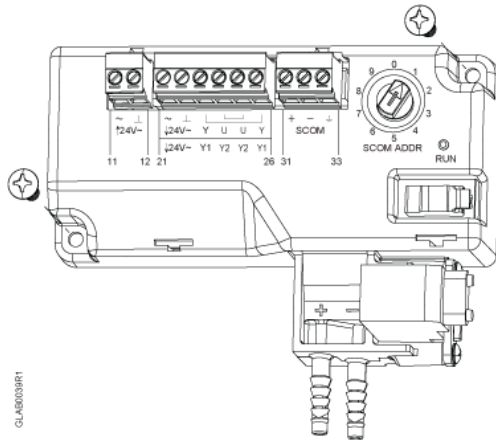

IP54 box mounting: The IP54 rated APS can only be mounted as shown.

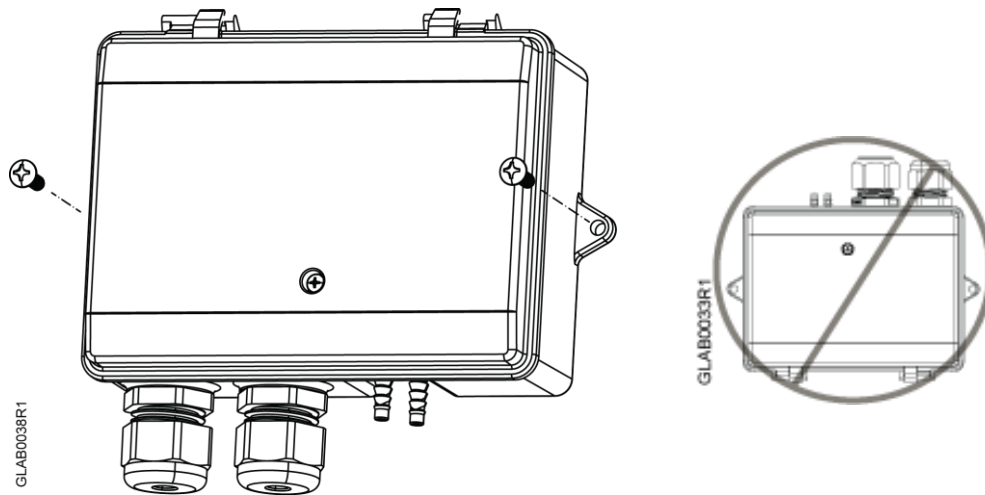

Installation



⚠ WARNING

No internal line protection for supply lines to external consumers

Risk of fire and injury due to short-circuits

- Adapt the line diameters as per local regulations to the rated value of the installed fuse.

The technical data must include the appropriate information on internal or external device protection.

Operation

Airflow sensing range: 0...1" WC. (250 Pa)

Accuracy: 1% of reading or 0.001" WC. (0.25 Pa), whichever is greater

Over-range detection: The APS provides a separate over-range detection allowing the controller to perform the correct action at a higher airflow.

Under-range detection: The APS provides a separate under-range detection allowing the controller to perform the correct action at a lower airflow.

Disposal



The device is considered an electronics device for disposal in terms of European Directive 2012/19/EU and may not be disposed of as domestic garbage.

- Dispose of the device through channels provided for this purpose.
- Comply with all local and currently applicable laws and regulations.

Warranty

Technical data on specific applications are valid only together with Siemens products listed under "Equipment combinations". Siemens rejects any and all warranties in the event that third-party products are used.

Technical data

Dimensions and Weight	
Dimensions DXA.S04P1 (IP20)	117 mm x 102 mm x 48 mm (4.6" H x 4.0" W x 1.9" D)
DXA.S04P1-B (IP54)	157 mm x 119 mm x 53 mm (6.2" H x 4.7" W x 2.1" D)
Weight DXA.S04P1 (IP20)	0.1 kg (5 oz.)
DXA.S04P1-B (IP54)	0.3 kg (11 oz.)

Power supply	
Operating voltage	AC 24V (+20%, -15%).
Frequency	50/60 Hz.
Power consumption excluding connected field devices	Max. 17 VA
Internal fuse	Resettable PTC.

* Do not use the voltage output on the DXR2.17C... to provide power to the APS (DXA.S04P1...).

Interfaces	
SCOM	Dedicated digital sensor communication. Baud rate: 115.2kbps. Short-circuit proof. Protection against faulty wiring at max. AC 24V.

Wiring connections	
Pluggable screw terminals	Copper wire or copper strands with ferrules 1 x 0.6 mm \varnothing to 2.5 mm ² (22 to 14 AWG) or 2 x 0.6 mm \varnothing to 1 mm ² (22 to 18 AWG) Copper strands without ferrules 1 x 0.6 mm \varnothing to 2.5 mm ² (22 to 14 AWG) or 2 x 0.6 mm \varnothing to 1.5 mm ² (22 to 16 AWG)
Slotted screws	Size 1, tightening torque 0.6 Nm (0.44 lb-ft)
Wiring lengths for signals.	SCOM RS-485 80 m (262 ft) Termination required >30m (100 ft) Signal lines 80 m (260 ft)

Ambient conditions and protection classification	
Classification as per EN 60730 Function of automatic control devices Degree of contamination Overvoltage category	Type 1 2 III.
Design type	Device suited for use with equipment of safety classes I and II.
Degree of protection of housing to EN 60529 Airflow pressure sensor With box cover	IP20. IP54.
Climatic ambient conditions <ul style="list-style-type: none"> Transport (packaged for transport) as per EN 60721-3-2 Operation as per EN 60721-3-3. 	<ul style="list-style-type: none"> Class 2K3 Temperature -25...70 °C (-13... 158 °F) Air humidity 5...95%. Class 3K5 Temperature -5...50 °C (23... 122 °F) Air humidity 5...95%.
Mechanical ambient conditions Transport as per EN 60721-3-2 Operation as per EN 60721-3-3	Class 2M2. Class 3M2.

Standards, directives and approvals	
Product standard	IEC/UL/EN 60730-1. part H.23 Emission and H.26 Immunity
EU conformity (CE)	Immunity IEC/EN 61000-6-2 Emission IEC/EN 61000-6-3
RCM conformity	AS/NZS 61000-6-3 : 2012
UL Approbation	UL916, http://database.ul.com
cUL	CSA C22.2 No 205
Federal Communications Commission	FCC CFR 47 Part 15 subpart B Class B.
Environmental compatibility	The product environmental declaration (Siemens Standard SN36350) contains data on environmentally compatible product design and assessments (RoHS compliance, materials composition, packaging, environmental benefit, disposal).

Connection Terminals

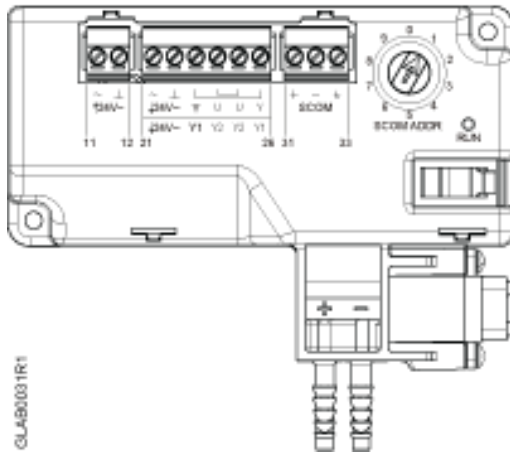

Pin	Description	Terminal
11, 12 power 24V~	Power supply SELV / PELV AC 24V	V~
	System neutral	⊥
21...26	Power	~
	System neutral	⊥
	Actuator connections	Y1, Y2
31...33	SCOM	+, -
	Isolated comm. ground reference	⊥
SCOM ADDR	SCOM address (0..9)	Rotary dial (default 1)
ΔP differential pressure detector	Connected to the higher pressure (interior diameter 3...8 mm tubing)	+
	Connected to the lower pressure (interior diameter 3...8 mm tubing)	-

Connection diagrams

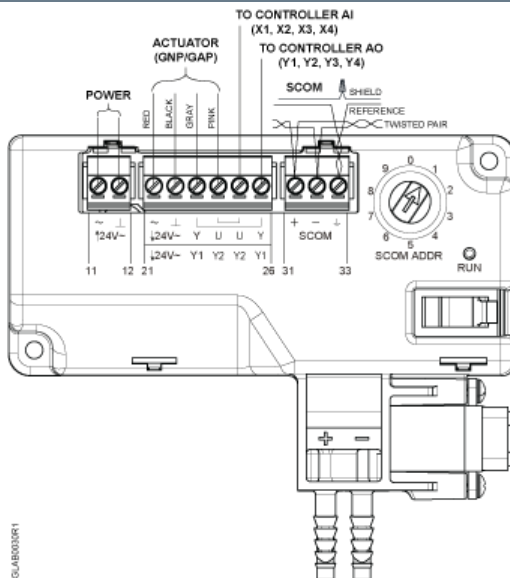

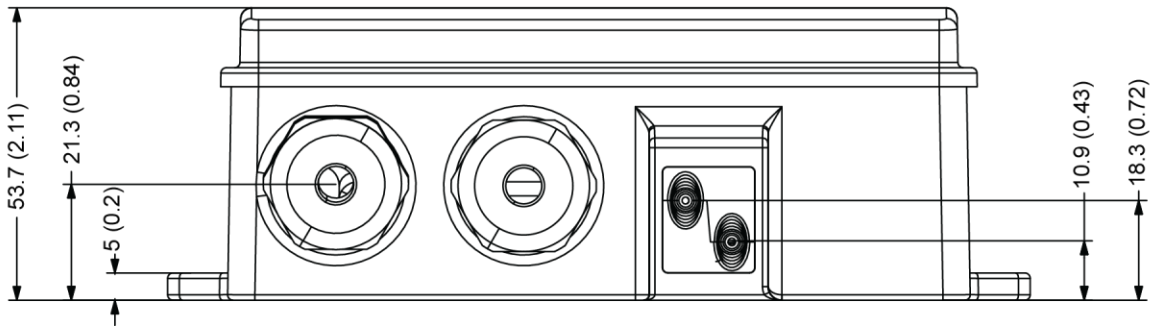
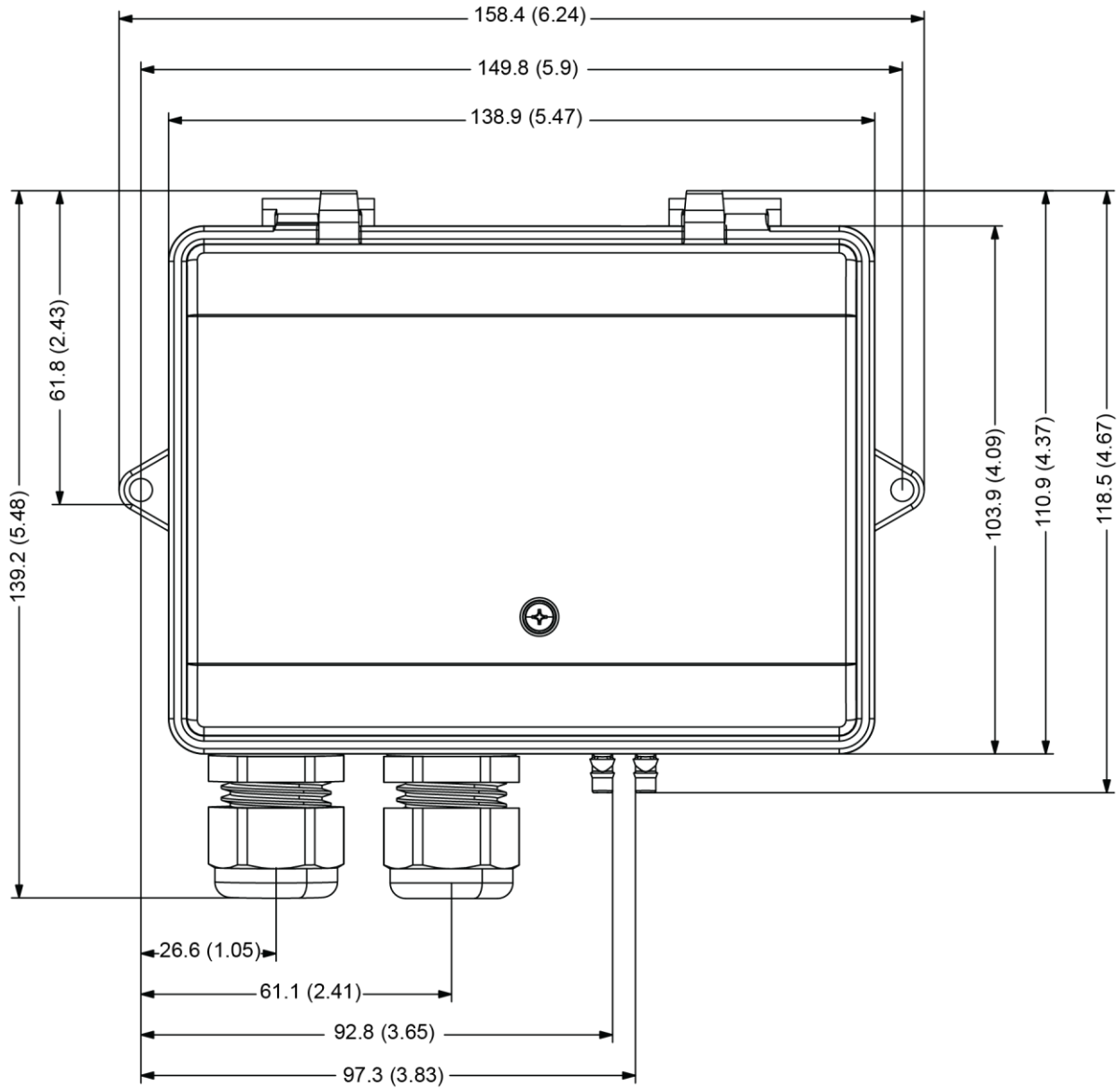

GLAB0035R1

Issued by
Siemens Industry, Inc.
Building Technologies Division
1000 Deerfield Pkwy
Buffalo Grove IL 60089
Tel. +1 847-215-1000

© Siemens Industry, Inc., 2017
Technical specifications and availability subject to change without notice.